

Electric submersible pumps with cutter system for sewage and effluent.

Barracuda GRP 56-111

Application

The installation of conventional sewer systems in areas of low population like small villages, farms or under difficult topographic conditions is often extremely expensive, mainly because of the high cost for large diameter pipework installation. HOMA provides the perfect, economical alternative with Barracuda grinder pump pressure sewage systems. The Barracuda pumps cut all solids present in the sewage into small particles. This allows the use of pipes from 50 mm diameter, which can be easily laid at low cost with a minimum of construction work.

The range of GRP 56–111 models offer unique hydraulic performance, combined with high efficiency and a supreme quality standard. These pumps are applied wherever extreme high head pumping capability up to 7 bar is required.

DIN EN 12050-1: Conformity and design approved and controlled by LGA.

Installation: Permanent with auto coupling system or with ringbase stand.

Pumped liquid: Waste water or sewage containing soft solids.

Max. liquid temperature: 40°C, short term up to 60°C.

Operation: Permanent (S1).

Design

Fully submersible, compact integrated motor-pump consisting of:

Pump: Single stage centrifugal pump with horizontal discharge DN 50.

Impeller: Open multi-channel impeller. Cutter system at pump inlet consisting of stationary cutter ring and blade rotor from hardened (45 rockwell C scale minimum) high alloy stainless steel.

Motor: Fully submersible, pressure-tight electric motor, three phase, oil-filled. Thermal sensors embedded in stator winding. Insulation class H. Degree of motor protection IP 68. Cable connection chamber totally isolated from motor housing.

Cable: H07RN-F7G1,5 and 5G 1,5
Model Ex: H07RN - F-PLUS 10G1,5 and 4G1,5.

Shaft/Bearing: Large diameter stainless

Performance

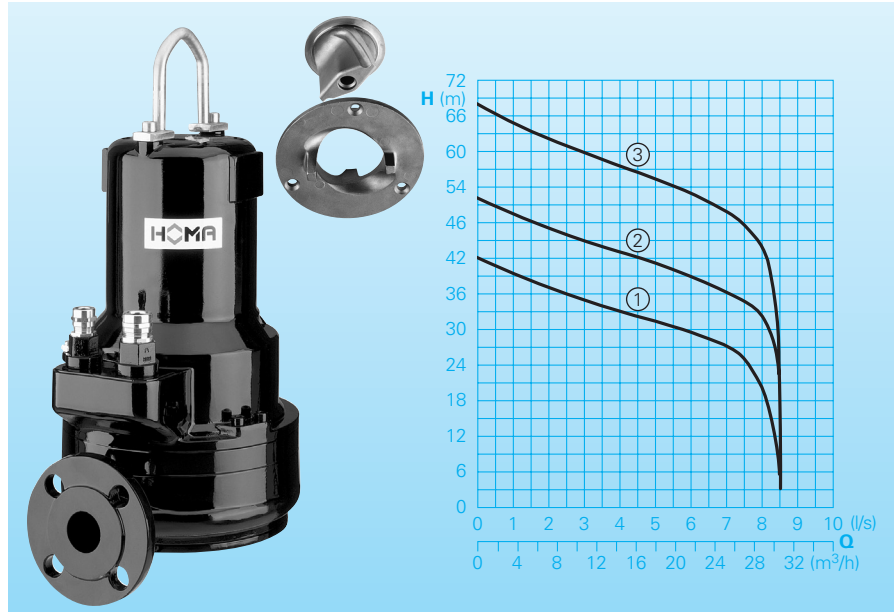

Technical Data

Curve No.	Pump type	Motor		Voltage 50 Hz (V)	Speed (rpm)	Nominal current (A)	Weight (kg)	
		P ₁ (kW)	P ₂ (kW)				Wet install.	Dry install.
①	GRP 56 (ET) D(Ex)	7,5	6,4	400/3Ph	2900	13,0	104	108
②	GRP 76 (ET) D(Ex)	7,5	6,4	400/3Ph	2900	13,0	104	108
③	GRP 111 (ET) D(Ex)	11,0	9,5	400/3Ph	2900	18,8	107	111

Discharge: DN 50
Cable length: 10 m

Model ET: EffTec-Motor with PermaCool system
Model Ex: explosion proof

steel rotor shaft, pre-lubricated bearings.

Seals: Combination of mechanical seals (silicon-carbide) in a separate oil-chamber. Oil inspection from outside. Electronic seal probe fitted into the oil chamber.

Motorjacket: All models available with PermaCool system for drywell installation or not fully submerged operation.

Explosion protection: All models available with explosion proof motors according to Ⓜ II 2 G Ex c d II B T4(T3).

Materials

Pump housing, motor housing, impeller	Cast iron EN-GJL-250
Cutter system	Stainless steel 1.4122
Mechanical seals	Silicon-carbide/ Silicon-carbide
Rotor shaft, screws, cooling jacket (U)	Stainless steel
Seal kit	Perbonane

Equipment supplied

Pump with 10 m of cable.

Dimensions and Installations (all dimensions in mm)

Free standing pump with ringbase stand
GRP 56 – GRP 111 (U) D (Ex)

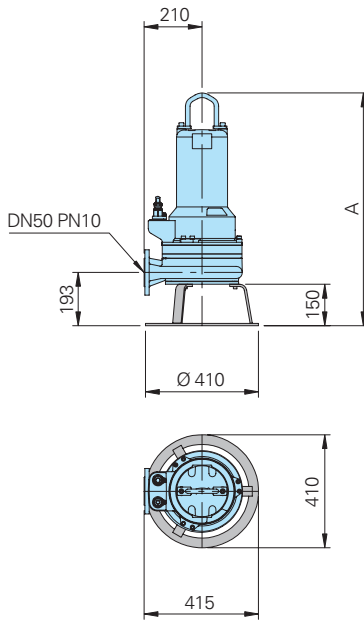

Permanent sump installation
Single pump station

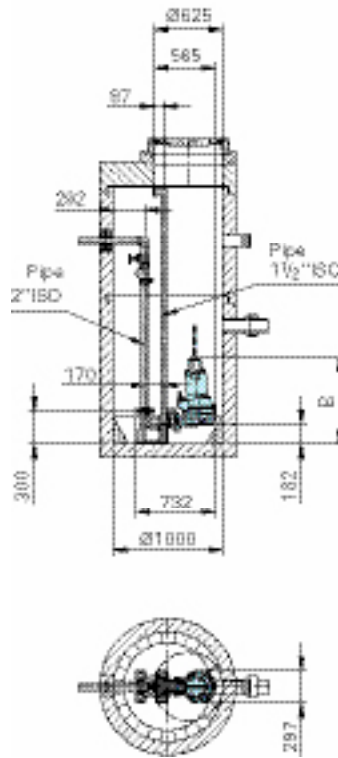

Twin pump station

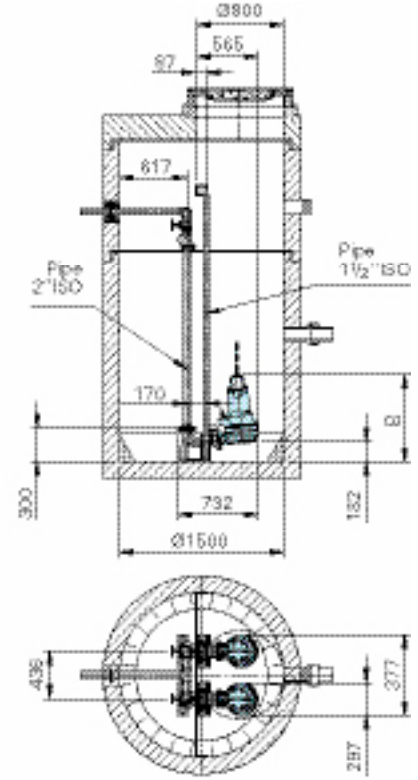

Permanent sump installation with auto-coupling system

Permanent installation utilizing a submerged auto-coupling guide rail system for automatic connection and disconnection of the pump from the pipework from outside the sump. Applicable for single and multi pump stations. Advantages: Little space requirement, easy pump service and maintenance.

Type	A	B
GRP 56 (ET)	771 (795)	790 (815)
GRP 76 (ET)	771 (795)	790 (815)
GRP 111 (ET)	844 (865)	862 (885)

Accessories

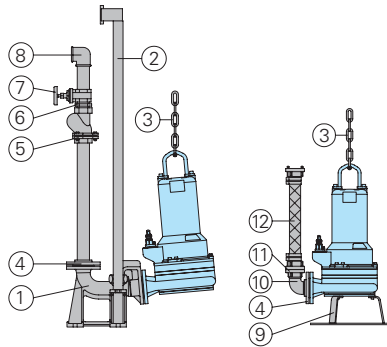

Part Description	Dim.	Part No.
① Auto-coupling system type KK50/50, with: - Cast iron auto-coupling with flange and thread - Cast iron flanged pump coupling - Cast iron upper slide rail bracket	DN50 DN50 BSP1/2"	8604012
○ Auto-coupling system complete or partial in stainless steel	all types	on request

Part Description	Dim.	Part No.
○ Screw-kits for installation of coupling system est		on request
○ Inter. upper slide rail bracket	Ø 1 1/2" für KK50	7322901
② Guide rails, pair, per m steel galvanized	1 1/2" dia.	2190155
stainless steel	1 1/2" dia.	2190254
③ Pump chain sets, testet. With shackle, One- or Two-strand, different lengths and load capacities		on request
④ Threaded flange	DN 50/ BSP 2" F	2215050
⑤ Cast iron swing check valve	BSP 2" F	2212903
⑥ Galvanized double nipple	BSP 2" M	200901
⑦ Bronze gate valve	BSP 2" F	2216020

Part Description	Dim.	Part No.
⑧ 90° galvanized elbow	BSP 2" F	2113606
T-piece for twin pump operation	BSP 2" F	2114306
⑨ Ring base stand		7321465
⑩ 90° galvanized elbow	BSP 2" M/F	2111506
⑪ STORZ-fixed coupling	C-BSP 2" M	2010204
⑫ Reinforced hose, per m (inner dia.)	50 mm Ø	2632050
STORZ-hose coupling with spigot	C-52 mm	2013003
Hose band	2"	2306009
Synthetic pressure hose with rubber lining and couplings, C-52 mm dia.	10 m 15 m 20 m 30 m	2611310 2611315 2611320 261133
○ Control panel for single or twin pump stations for automatic operation		On request



HOMA Pumpenfabrik GmbH
P.O.Box 22 63, D-53814 Neunk.-Seelscheid
Tel. +49 (0) 22 47/702-0, Fax +49 (0) 22 47/702-44
e-mail: info@homa-pumpen.de
www.homapumps.com