

**Submersible drainage pumps
for hot clear- and drainage water.
Free passage 10–28 mm.**

H307, H313, H328 V

Application

Pumps for pumping clean or soiled water at high temperatures. With the advantage of thick wall casting for dissipation of heat and viton seals, they are the ideal solution to pump condensate, clear water or drainage water up to 90°C, also for steam condensate. The models H 307 and H 313 are used for pumping clear water or drainage water up to 10 mm spherical clearance, model H 328 V up to 28 mm spherical clearance. They are suitable for laundries, car washes, food industries and many other applications.

Installation: Stationary or mobile. Version with float switch for use as automatic water level controlled drainage pump.

DIN EN 12050-2: Conformity and design tested and monitored by the LGA.

Pumped medium: Clear- or domestic drainage water, steam condensate.

Max. temperature of pumped medium: 90°C.

Operating mode: Intermittent operation.

Design

Fully submersible pump, consisting of:

Pump: Single-stage with horizontal discharge.

Impeller: H307/H313 open multi-channel impeller, free passage 10 mm. H328V vortex impeller, free passage 28 mm.

Motor: Fully submersible motor, sealed against pressurised water, oil-filled. Insulation class H. Protection rating IP 68.

Single-phase model with thermal sensor in the winding for temperature monitoring. Electrical compartment is separate from motor.

Connecting cable: BI HF-J 4 x 1,5
Model WA: BI HF-J 5 x 1,5

Shaft/bearing: strongly dimensioned-chrome steel shaft, lifetime-lubricated roller bearings.

Seal: Combination of mechanical seal and radial shaft seal that is independent of the direction of rotation

Conveying capacities

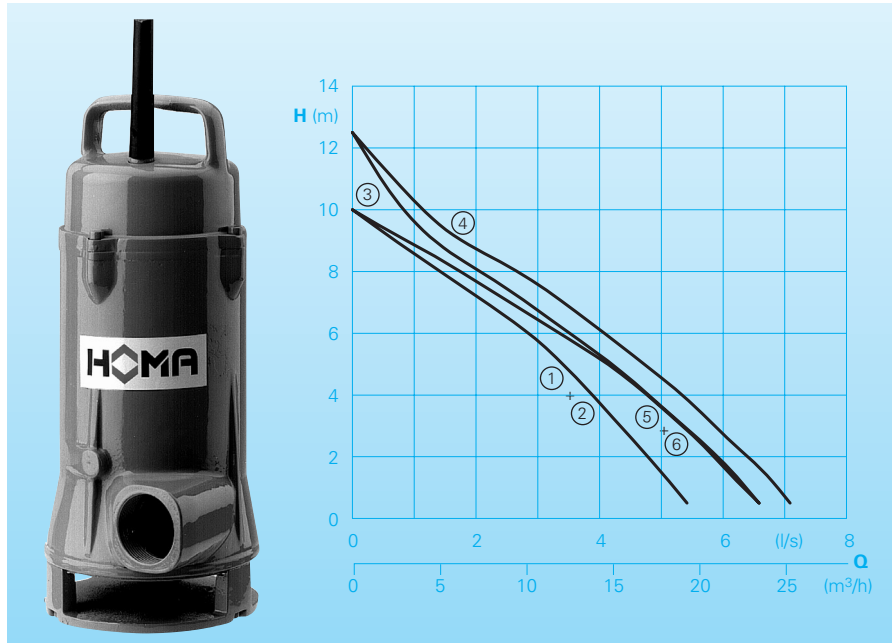

Technical data

Curve No.	Pump type	Motor input		Voltage 50 Hz (V)	Nominal current (A)	Weight (kg)
		P ₁ (kW)	P ₂ (kW)			
①	H307 W (A)	0,8	0,5	230/1Ph	3,4	18
②	H307 D (A)	0,7	0,5	400/3Ph	1,3	18
③	H313 W (A)	1,0	0,7	230/1Ph	4,3	18
④	H313 D (A)	1,2	0,9	400/3Ph	2,2	20
⑤	H328 V W (A)	1,2	0,9	230/1Ph	5,2	20
⑥	H328 V D (A)	1,2	0,9	400/3Ph	2,2	20

Rotational speed: 2900 Rpm
Discharge: BSP1 1/2

Model A: With automatic float switch HOMA-Nivomatik

Materials

Pump housing, Impeller, Motor housing	Cast iron EN-GJL-250
Motor shaft	Stainless steel
Mechanical seal	SiC/SiC
Elastomers	VITON
Connecting cable	Silicon

Scope of supply

Pump with 10 m connecting cable

Model W (230 V / 1 Ph):

With switchgear W1 with motor protection, ON-OFF-switch and mains plug, capacitor.

Model D (400 V / 3Ph):

With switchgear D32 with motor protection, ON-OFF-switch and direction reversal plug.

Model A: Additionally with automatic float switch HOMA-Nivomatik, switchgear WA1 or DA10/23 with MANU-AL-AUTO-switch.

Dimensions and installation example (all dimensions in mm)

**H307,
H313**

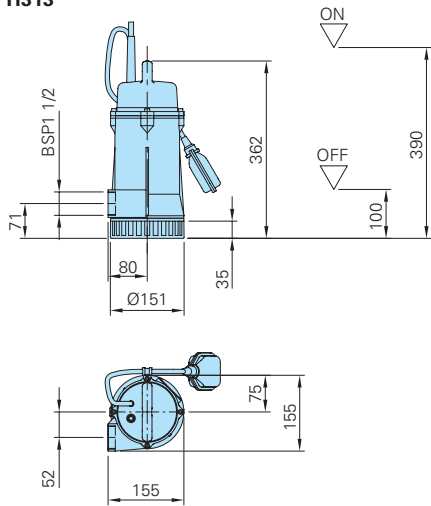

H328 V

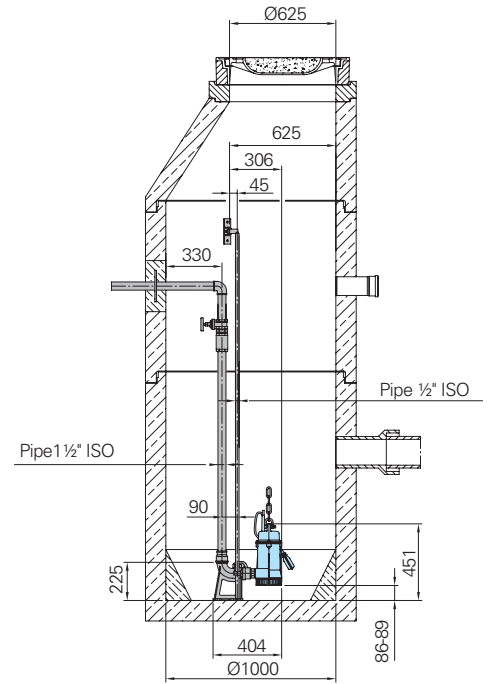
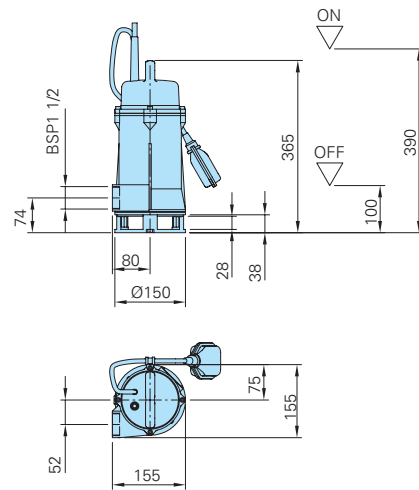

Shaft installation with automatic coupling system.

The pump is simply pulled up on the solid two-pipe guide for maintenance or replacement without having to walk on the shaft. If it is drained again, it will automatically couple to the pressure line. This setup is possible for single and multiple pump stations. Advantages: small space requirement, particularly service-friendly and economical.

Accessories

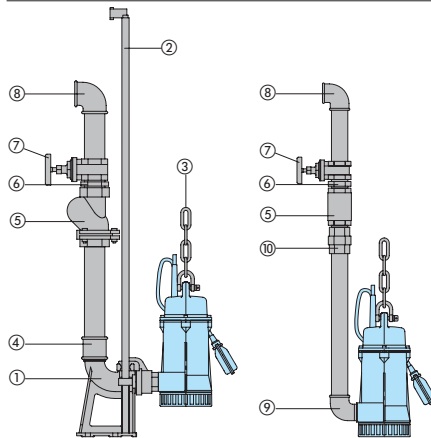

Description	Size	Part no.
① Automatic coupling system GG with mating flange with double nipple, base elbow with thread and slide rail bracket KK50/BSP1 1/2"	BSP2"/BSP1 1/2"	8604000
○ Coupling system completely or partly in stainless steel	all	on request
○ Screw-Kits for fastening coupling systems		on request

Description	Size	Part no.
Intermediate bracket for slide rail bracket extension	Ø 1/2"	7320271
② Guide rails, in pairs, per m		
Galvanised steel	Ø 1/2"	2190085
Stainless steel	Ø 1/2"	2190250
③ Pump chain sets, tested. With shackle, single or dual row, different lengths and load bearing capacities		on request
④ Double socket, galvanised	BSP 2" F	2109102
	BSP 2" F x BSP 1 1/2" F	2102210
⑤ Non-return ball valve GG	BSP 1 1/2" F	2212902
	BSP 2" F	2212903
⑥ Double nipple, galvanised	BSP 1 1/2" M	2009020
	BSP 2" M	2009018
⑦ Shut-off gate valve MS	BSP 1 1/2" F	2216015
	BSP 2" F	2216020
⑧ 90° angle, galvanised	BSP 1 1/2" F	2113605
	BSP 2" F	2113606
T-piece for merging the pressure pipe in double pump stations	BSP 1 1/2" F	2114302
	BSP 2" F	2114306
⑨ 90° angle, galvanised	BSP 1 1/2" F/M	2111505
	BSP 2" F/M	2111506
⑩ Transitional screw mounting, galvanised	BSP 1 1/2" M/F	2114305
○ STA-hose-screw connection, brass	BSP 1 1/2" M	2001513
STORZ-fixed coupling	C-G 1 1/2" M	2010003

Description	Size	Part no.
○ PVC-hose, per m	1 1/2" Ø 38 mm	2621500
Plastic spiral hose, per m	Ø 50 mm	2632050
STORZ-hose-coupling	C-38 Ø	2013002
	C-52 Ø	2013003
Hose clamp	1 1/2"	2304854
	2"	2306009
○ Residual current device 2-poles, Fi 16/0,03 A		1561160
○ Mains-dependant alarm control unit AL3 with connector for 9 V rechargeable battery (see below) for operation independent of mains power supply, with built-in signal transmitter, float switch and 10 m of cable. Main phase connection 230V/1Ph		1586141
Battery 9V for mains-independent alarm		1952215
○ For pump controllers and control units for mobile and stationary applications, measuring systems and monitoring devices, see HOMA accessories		

